



## Downstream pressure reducing valve with two set points Mod. XLC 310/410-ND

The CSA model XLC 310/410-ND is a globe pattern hydraulically operated automatic control valve that reduces and stabilizes the downstream pressure to two pre-set and adjustable values, regardless of variation in demands and upstream pressure conditions, usually corresponding to night and day regulation. Normally equipped with visual position indicator, the valve is designed to reduce head loss, throttling noise and cavitation damage. The CSA pressure reducing valve XLC 310/410-ND is extremely versatile and mainly used for pressure management and water loss reduction campaigns.

### Applications

- A well-planned pressure management program will extend the life of the system increasing safety and reliability. The automatic control valve CSA XLC Model. 310/410-ND, thanks to the battery operated programmer, is designed to automatically optimize the downstream pressure regulations in two steps, both adjustable, where the lower values usually corresponds to night time low consumption requirements.

### Accessories

- Linear position transmitter with 4-20 mA output Mod. CSA CSPL.
- On-off position transmitter Mod. CSA CSPO.
- Pressure measurement kit.
- Self-flushing and high capacity filter.

### Note to the engineer

- CSA anti-cavitation low flow stability plugs are recommended to provide an accurate regulation in case of low flow conditions.
- A minimum length of 3 DN downstream of the valve is recommended for the best accuracy.
- The programmer is battery operated with an average lifespan of 13 months if used on a daily basis, different solutions on request.

### Additional features

- XLC 310/410-ND-FR night and day downstream pressure reduction with back-flow prevention.
- XLC 310/410-ND-H night and day downstream pressure reduction with high sensitivity pilot.
- XLC 310/410-ND-5 night and day downstream pressure reduction with solenoid control.

### Working conditions

- Fluid: treated water.
- Minimum operating pressure: 0,7 bar.
- Maximum operating pressure: 16 bar.
- Maximum temperature: 70°C.

### Downstream pressure pilot adjustment range

- Blue spring: 0,7 to 7 bar.
- Red spring: 1,5 to 15 bar.

## Operating principle

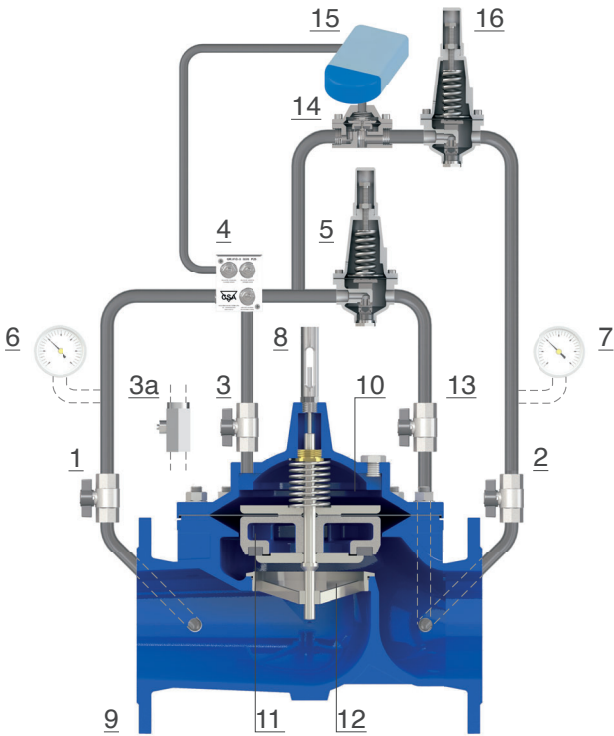

The valve is operated by two 2 ways pilot (5-16), for pressure reduction with pre-set set and adjustable values, activated by a battery operated timer (15) acting on a flow accelerator (14). During night time regulation (low pressure) pilot 5 is working being the two ways valve (14) closed. Should the downstream pressure rise above the pilot (5) set point the latter will throttle and limit the flow to direct inlet pressure to the main chamber (10), to generate the head loss required for the valve (9) to reduce and stabilize the downstream pressure. During the day, or according to the customer's program of the timer (15), the pilot (16) is activated, and being its set point higher than the night time pilot (5) the latter will be forced to the closed position. The flow in and out of the main chamber (10) is controlled by the CSA exclusive unit regulation device with filter called GR.I.F.O. (4) and provided with three needle valves and flow stabilizers, needed for the valve's response time and accuracy also in case of rapid variation in demand.

## Installation layout

The recommended XLC 310/410-ND installation lay-out includes sectioning devices (1, 2) and by-pass for maintenance operations, and a filter (3) to prevent dirt from reaching the control valve. The direct acting pressure reducer VRCD (4) is the best choice on the by-pass thanks to its reliability also after long periods of inactivity. Anti-surge combination air valves FOX 3F AS (6, 7) are recommended upstream and downstream as well as a pressure relief valve VSM (5) to prevent rise in pressure on the line.

