



Wastewater combination underground air valve Mod. SCF-U

The underground air valve has been designed to provide the proper solution for those locations requiring cost saving, frost protection, installation under roads, pavements, buildings. The air valve will ensure the proper operation of sewage lines allowing the release of air pockets during working conditions, the evacuation and the entrance of large volumes of air during filling and draining operations.



Technical features and benefits

- The model is designed to provide an alternative solution to conventional air valves installations avoiding chambers, structures, pits and sectioning devices between the air valve and the pipeline.
- Stand pipe in PVC with drain port in the lower part which avoids accumulation of water inside the pipe.
- Various sizes and drilling of the flange.
- CSA wastewater combination air valve automatically operated by the flow medium, available in different versions, removable from the top by the handle connected to its upper part.
- Thanks to the drain pipe and the sectioning device included in the base, with manoeuvring rod operable from the top, maintenance can be carried out without interrupting the flow in the main pipe or digging.

Applications

- At high points and changes in slope of sewage lines.
- Pressurized sewage systems.
- In areas exposed to frost, under the roads, buildings.

Operating principle



Discharge of large volumes of air

During the pipe filling it is necessary to discharge air as liquid flows in. The SCF 2", thanks to an aerodynamic body and deflector, will make sure to avoid premature closures of the mobile block during this phase.



Air release during working conditions

During operation the air produced by the pipeline is accumulated in the upper part. Little by little it is compressed and its volume increases, pushing the liquid level downwards and allowing the air release through the nozzle.



Entrance of large volumes of air

During pipeline draining, or pipe bursts, it is necessary to bring in as much air as the quantity of outflowing liquid. This is to avoid negative pressure and serious damages to the pipeline and the entire system.

Installation

The installation simply required a derivation from the main line with the same DN and PN of the air valve, and a man-hole on top to allow for maintenance operation so the entire CSA underground air valve system, equipped with a drain, can be buried below ground. Usually gravel stones are located at the bottom where drain is present and on the top around the manhole and the upper part of the air valve container. A specifically designed gear box operated horizontal sliding disc valve - situated at the base of the assembly - allows for the air valve disconnection and maintenance from ground level even when the system is under pressure. The air valve can be removed by means of an intuitive and easy lever mechanism.

Maintenance and extraction

Before being maintained the SCF-U needs to be isolated from the main pipe, this is done by acting on the rod to close the passage through the CSA sectioning device located at the bottom. Picture 1 shows the air valve without and subject to this maneuver. Once the air valve has been isolated simply act on the handle to rotate and pull it up from the connection as shown in the picture nr 2. The intuitive mechanism allows for a easy and friendly usage of the equipment. Simply follow the instruction backwards after having inspected the air valve



Technical data

Air flow performance charts

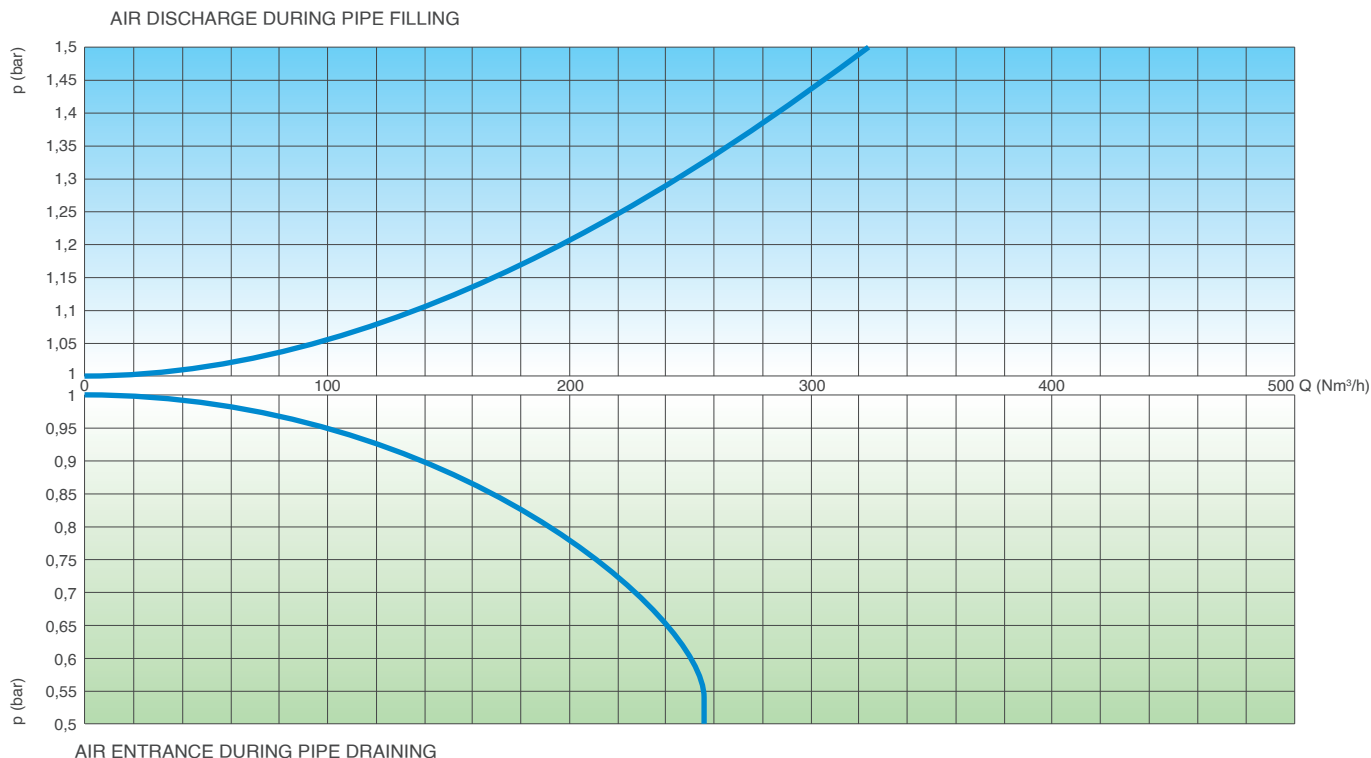

The air flow charts were created in Kg/s from laboratory tests and numerical analysis, then converted in Nm³/h using a safety factor.

Working conditions

- Water and waste water max. 60°C.
- Maximum pressure 16 bar.
- Minimum pressure 0,2 bar. Lower on request.

Standard

- Certified and tested in compliance with EN-1074/4.
- Manufactured with 2" inlet; supplied on request with flanges according to EN 1092/2 / ANSI.
- Epoxy painting applied through fluidized bed technology blue RAL 5005.
- Changes on the flanges and painting details available on request.

Nozzle choice

Nozzle diameter in mm according to the size of the air valve and the PN.

PN 10	PN 16
1,7	1,7

Weights and dimensions

C	A	B
inch	mm	mm
2"	410	705

All values are approximate, consult CSA service for more details.

AIR RELEASE DURING WORKING CONDITIONS

nozzle diameter (mm)

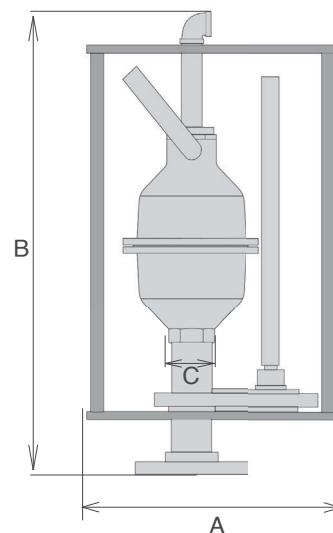
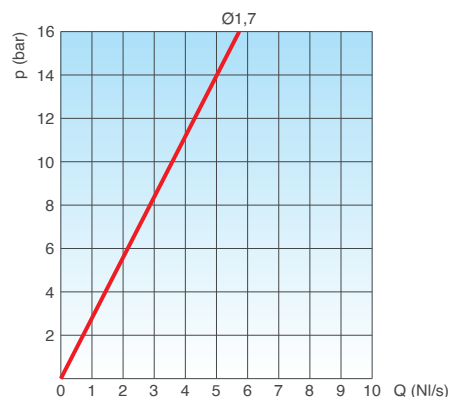

Technical details

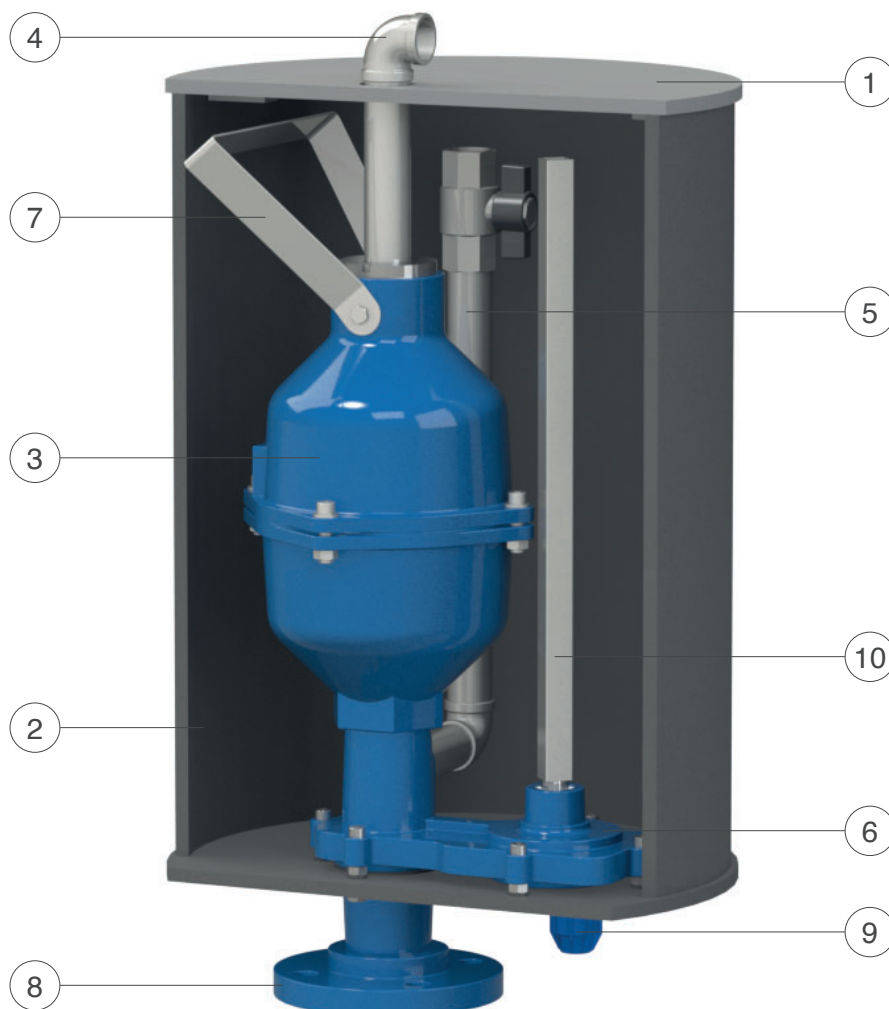

N.	Component	Material
1	Cover	PVC
2	Stand pipe	PVC
3	Air valve SCF 2"	in different executions (see SCF 2" technical details)
4	Conveyance pipe	stainless steel or plastic
5	Drain pipe	stainless steel or plastic
6	Sectioning device	ductile cast iron GJS 450-10 epoxy coated, stainless steel, NBR
7	Handle	stainless steel
8	Flange	steel epoxy coated
9	Drain	polypropylene
10	Manoeuvring rod	zinc-plated steel

The list of materials and components is subject to changes without notice.