

Pressure management downstream pressure reducing valve Mod. XLC 310/410-ND-H



The CSA model XLC 310/410-ND-H is a globe pattern hydraulically operated automatic control valve that reduces and stabilizes the downstream pressure to two pre-set and adjustable values, regardless of variation in demands and upstream pressure conditions, usually corresponding to night and day regulation. Designed to reduce head loss, throttling noise and cavitation damage the valve switches from one pressure to the other according to the flow rate, within an adjustable range. XLC 310/410-ND-H is extremely versatile and mainly used for pressure management and water loss reduction campaigns.

Applications

- A well-planned pressure management program will extend the life of the system increasing safety and reliability. The automatic control valve CSA XLC Model 310/410-ND-H, thanks to high sensitivity pilots, is designed to automatically perform the downstream pressure regulations in two values, both adjustable, where the lower values usually corresponds to night time low consumption requirements.

Accessories

- Linear position transmitter with 4-20 mA output Mod. CSA CSPL.
- On-off position transmitter Mod. CSA CSPO.
- Pressure measurement kit.
- Self-flushing and high capacity filter.

Note to the engineer

- CSA anti-cavitation low flow stability plugs are recommended in case of low flow.
- A minimum length of 3 DN downstream of the valve is recommended for the best accuracy.
- The flow rate switching point, from one downstream pressure value to the other, is adjusted through an high sensitivity pilot on a scale provided according to the application.

Additional features

- XLC 310/410-ND-H-FR night and day pressure reduction with back-flow prevention.
- XLC 310/410-ND-H-H night and day downstream pressure reduction with high sensitivity pilot.
- XLC 310/410-ND-H-5 night and day downstream pressure reduction with solenoid control.

Working conditions

- Fluid: treated water.
- Minimum operating pressure: 0,7 bar.
- Maximum operating pressure: 16 bar.
- Maximum temperature: 70°C.

Downstream pressure pilot adjustment range

- Blue spring: 0,7 to 7 bar.
- Red spring: 1,5 to 15 bar.

Operating principle

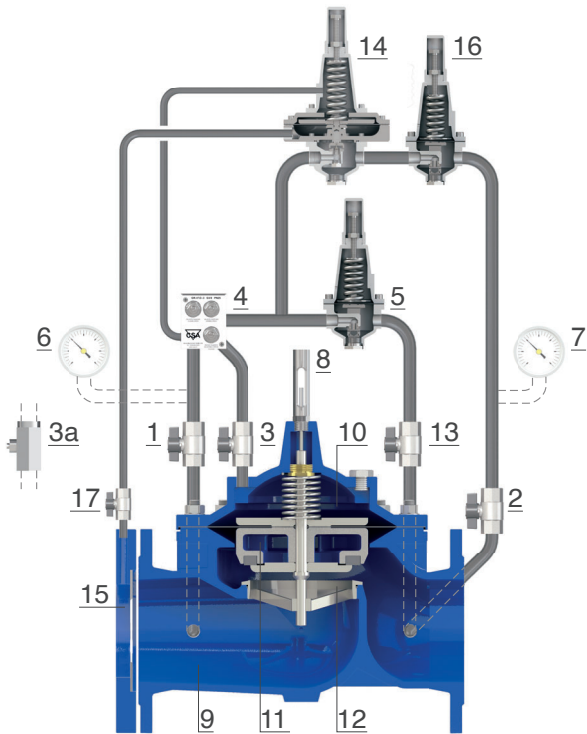

The valve is operated by two 2 ways pilot (5-16), for pressure reduction with pre-set set and adjustable values, activated by a third high accuracy flow sensing pilot (14), connected to a flanged orifice assembly located upstream (15). The flanged orifice is sized according to the application, user can then operate on the regulation screw to determine the flow above which the high pressure pilot will begin to work. Should it remain below such point the pilot (14) is closed diverting all flow and pressure to operate the lower pressure pilot (5). Once the flow has reached the triggering point pilot (14) will open allowing flow to circulate through the pilot (16), which will increase the pressure on the downstream side of the valve by closing the pilot (5), set to a lower value. The flow in and out of the main chamber (10) is controlled by the CSA exclusive unit regulation device with filter called GR.I.F.O. (4) provided with three needle valves and flow stabilizers, needed for the valve's response time and accuracy also in case of rapid variation in demand.

Installation layout

The recommended XLC 310/410-ND-H installation lay-out includes sectioning devices (1, 2) and by-pass for maintenance operations, and a filter (3) to prevent dirt from reaching the control valve. The direct acting pressure reducer VRCD (4) is the best choice on the by-pass thanks to its reliability also after long periods of inactivity. Anti-surge combination air valves FOX 3F AS (6, 7) are recommended upstream and downstream as well as a pressure relief valve VSM (5) to prevent rise in pressure on the line.

