

Downstream pressure reducing stabilizing valve with over pressure guard Mod. XLC 310/410-G



The CSA model XLC 310/410-G is a globe pattern hydraulically operated automatic control valve that reduces and stabilizes the downstream pressure to a constant value, regardless of variation in demands and upstream pressure conditions. Equipped with an additional pilot the valve will make sure to maintain the downstream pressure within the required set point without any unwanted increase and consequent damages to the system. Entirely made in ductile cast iron with FBT epoxy coating and stainless steel, the valve is designed to reduce head loss, throttling noise and cavitation damage.

Applications

- Downstream of pumps to reduce the pressure on the main supply line.
- Installed in derivation from the main line to stabilize the pressure of secondary line and water users.
- As a protection against rise in pressure of industrial equipment and civil installations.
- On the inlet supply line of storage tanks to stabilize pressure and flow required for the level control.

Accessories

- Linear position transmitter with 4-20 mA output Mod. CSA CSPL.
- On-off position transmitter Mod. CSA CSPO.
- Pressure measurement kit.
- Self-flushing and high capacity filter.

Note to the engineer

- CSA anti-cavitation low flow stability plugs are recommended to provide an accurate regulation in case of low flow conditions.
- A minimum length of 3 DN downstream of the valve is recommended for the best accuracy.
- The set point value of the pressure guard pilot should remain within 0,6 bar tolerance on the PRV value.

Additional features

- XLC 310/410-FR downstream pressure reducing with back-flow prevention.
- XLC 310/410-H downstream pressure reducing with high sensitivity pilot.

Working conditions

- Fluid: treated water.
- Minimum operating pressure: 0,7 bar.
- Maximum operating pressure: 25 bar.
- Maximum temperature: 70°C.

Downstream pressure pilot adjustment range

- Blue spring: 0,7 to 7 bar.
- Red spring: 1,5 to 15 bar.
- Higher values up to 25 bar on request.
- Values lower than 0,7 available with high sensitivity pilots.

Over pressure guard pilot adjustment range

- Blue spring: 0,7 to 7 bar.
- Red spring: 1,5 to 15 bar.
- Values lower than 0,7 available with high sensitivity pilots.

Operating principle

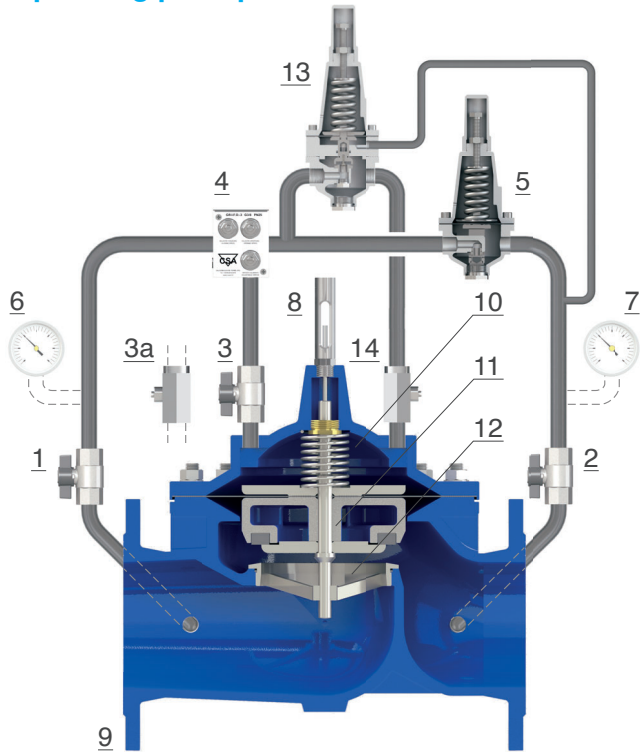

The CSA model XLC 310/410-G is an automatic control valve operated by a 2 ways pilot (5) for pressure reduction with pre-set set and adjustable value. Should the downstream pressure rise above the pilot set point the latter will throttle and limit the flow to direct inlet pressure to the main chamber (10), thus pushing down the obturator (11) to generate the head loss required for the valve (9) to reduce and stabilize the downstream pressure to a constant value. Should the downstream pressure fall below the pilot set point the obturator (11) will raise increasing the passage through the seat (12), thus reducing the head loss followed by the rise in pressure. The pressure guard pilot (13) senses the variation of the downstream pressure, should the latter rise above the set point the pilot (13) will open diverting the flow towards the control chamber, thus preventing any possible pressure increase above the PRV pilot (5) set point value. Thanks to the isolation ball valves (1-2-3) the control circuit and its components can be maintained without interrupting the flow through the main line.

Installation layout

The XLC 310/410-G installation lay-out includes sectioning devices (1, 2) and by-pass for maintenance operations, and a filter (3) to prevent dirt from reaching the control valve. The pressure reducer VRCD (4) is the best choice on the by-pass thanks to its reliability also after long periods of inactivity. Anti-surge combination air valves FOX 3F AS (6, 7) are recommended upstream and downstream as well as a pressure relief valve VSM (5) as a back up to prevent rise in pressure on the main line.

