



Upstream pressure sustaining automatic valve Mod. XLC 320/420-S

The CSA Model XLC 320/420-S is a globe pattern hydraulically operated automatic control valve that, installed in-line, will sustain the upstream pressure to a pre-set and adjustable value regardless of variations in demand. Normally equipped with visual position indicator and entirely made in ductile cast iron with FBT epoxy coating and stainless steel, the valve is designed to reduce head loss, throttling noise and cavitation damage. The XLC 320/420-S is extremely versatile and can be used for a wide range of applications in combination with several CSA accessories and additional functions.

Applications

- Downstream of pumps to prevent overload and for cavitation protection.
- On the inlet supply line of storage tanks to stabilize pressure and flow required for the level control.
- On gravity fed supply lines to ensure the minimum pressure to consumers located at higher elevation zones, in case of high consumption of the lower zones.

Accessories

- Linear position transmitter with 4-20 mA output Mod. CSA CSPL.
- On-off position transmitter Mod. CSA CSPO.
- Pressure measurement kit.
- Self-flushing and high capacity filter.

Note to the engineer

- Inlet pressure, outlet pressure, flow rate and application are required for the proper sizing and cavitation analysis.
- CSA anti-cavitation low flow stability plugs are recommended to provide an accurate regulation in case of low flow conditions.
- A minimum length of 3 DN upstream of the valve is recommended for the best accuracy.

Additional features

- XLC 320/420-S-FR pressure sustaining valve with back-flow prevention.
- XLC 320/420-S-5 pressure sustaining valve with solenoid control.
- XLC 320/420-S-H pressure sustaining valve with high sensitivity pilot.

Working conditions

- Fluid: treated water.
- Minimum operating pressure: 0,7 bar.
- Maximum operating pressure: 25 bar.
- Maximum temperature: 70°C.

Upstream pressure pilot adjustment range

- Blue spring: 0,7 to 7 bar.
- Red spring: 1,5 to 15 bar.
- Higher values up to 25 bar on request.

Operating principle

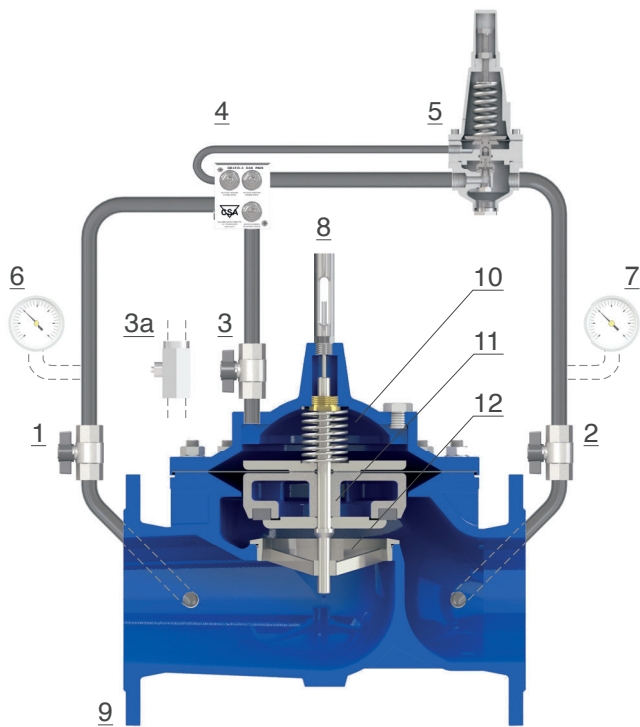

The CSA Model XLC 320/420-S is an automatic control valve operated by a high sensitivity two ways pilot (5), with pre-set and adjustable set point value, sensing the upstream pressure from the GR.I.F.O. (4). Should the line pressure rise above the pilot's set point the latter will open thus relieving the chamber (10) and moving the obturator (11) upwards, to discharge water and pressure through the main valve (9) downstream protecting the system. Should the upstream pressure be lower than the pilot's set point the latter will throttle (close eventually) diverting all pressure towards the main chamber (10) thus pushing the obturator (11) onto the seat (12), interrupting the flow rate.

The flow in and out of the main chamber is controlled by the CSA exclusive unit flow GR.I.F.O. (4) providing accuracy and absence of unwanted chattering.

Installation layout

The recommended installation lay-out of the CSA XLC 320/420-S, used as a pressure sustain in-line, includes sectioning devices (1, 2) and by-pass for maintenance operations, and a filter (3) to prevent dirt from reaching the control valve. The direct acting pressure sustain valve CSA Mod. VSM (4) is the best choice on the by-pass thanks to its reliability also after long periods of inactivity. Anti-surge combination air valves CSA Mod. FOX 3F AS (5, 6) are recommended upstream and downstream of the installation.

