



On-off solenoid automatic control valve Mod. XLC 350/450

The CSA Model XLC 350/450 is a globe pattern hydraulically operated automatic control valve that opens and closes in response to signals applied to the solenoid on the circuit, regardless of upstream pressure variations. Thanks to a CSA needle valve located on the chamber the reaction time can be adjusted, to prevent water hammer effects during the closing phase. Normally equipped with visual position indicator and entirely made in ductile cast iron with FBT (fluid bed technology) epoxy coating and stainless steel, the valve is designed to reduce head loss, throttling noise and cavitation damage.

Applications

- On main supply lines and water distribution networks to interrupt water supply in case of alarms and emergencies.
- In combination with an electric float for tank level regulation and control.
- As a system protection to shut-off in case of burst events.
- In filtration systems for back flushing.
- On storage tanks for automatic refreshing.

Accessories

- On-off position transmitter Mod. CSA CSPO.
- Pressure measurement kit.
- Self-flushing and high capacity filter.
- CSFL mechanical flow regulator.

Note to the engineer

- Inlet pressure, outlet pressure, flow rate and application are required for the proper sizing and cavitation analysis.
- Recommended flow rate and operating conditions on the XLC series engineering.
- CSA anti-cavitation low flow stability plugs are recommended to provide an accurate regulation in case of low flow conditions.

Additional features

- XLC 350/450-FR on-off solenoid control valve with back-flow prevention system.
- XLC 350/450-R on-off solenoid control valve with surge prevention system.

Working conditions

- Fluid: treated water.
- Minimum operating pressure: 0,7 bar.
- Maximum operating pressure: 16 bar. Higher on request.
- Maximum temperature: 70°C.

Solenoid electrical data

- Voltages: 24 V DC, 24 V/50 Hz, 230 V/50 Hz. Other voltages on request.
- Power consumption: inrush AC (VA) 24, hold AC (VA) 17 (8 W), DC hot/cold coil 8/9 W.

Operating principle (for DN 150-600)

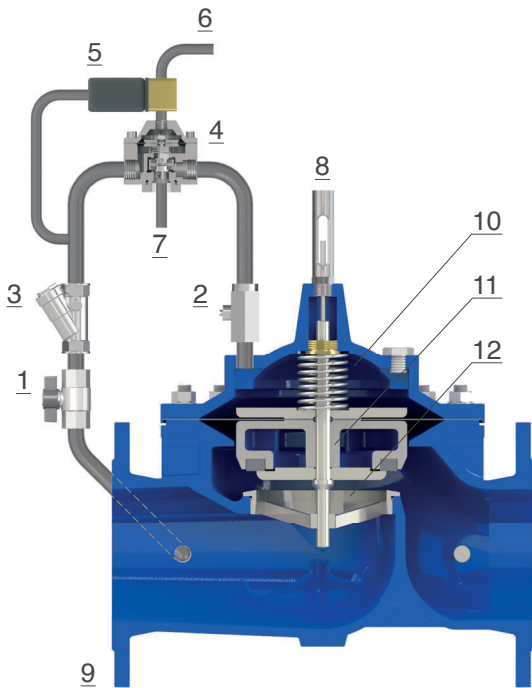

The CSA model XLC 350/450 is operated by a solenoid (5) working in combination with a flow accelerator or as a standalone unit, receiving impulses by remote or by a CSA controller, to perform either a fully closed or open function depending on what the valve is supposed to do in absence of power supply. The hydraulic accelerator (4) is present from DN 150 mm and above. In case of a normally open valve, for example, when the impulse is sent to the solenoid (5), the upstream pressure is diverted into the main chamber (10) directly, or through the hydraulic accelerator (4), pushing the obturator (11) towards the seat (12) then interrupting the supply. Should the signal be removed pressure will be taken out of the main chamber (10) directly or through the hydraulic accelerator (4), to lift the obturator (11) upwards then opening the main valve (9). Pressure in and out of the main chamber (10) is controlled by the CSA needle valve (2) needed for the valve's response avoiding possible surges and rapid pressure fluctuations. A filter (3) will protect the solenoid and the rest of the circuit from dirt.

Installation layout

The picture shows the layout of the CSA XLC 350/450 linked to a CSA controller (4) or any other electronic device sending impulses. In this case an electric float (2) is used for water tank level regulation, according to the function required. Sectioning devices (1) are important for maintenance operations as well as a filter (3) to prevent dirt from entering the valve. Anti-surge combination air valves FOX 3F AS are recommended upstream of the installation for air release during operating conditions and pipe filling.

