



Butterfly Valve EUROSTOP Motorizable type





Index

Butterfly Valve Motorizable type Eurostop	2
Range	3
Material and coating	
■ Versions DN150-800 PN10 - DN150-700 PN16 - DN150-600 PN25	4
■ Versions DN900-2000 PN10 - DN800-2000 PN16 - DN700-2000 PN25	5
Dimensions and mass	
■ Motorizable Version PN10	6
■ Motorizable Version PN16	7
■ Motorizable Version PN25	7
Gearbox type and handwheel	
■ Motorizable type PN10	8
■ Motorizable type PN16	9
■ Motorizable type PN25	10
Gearbox type and handwheel	10
Marking	11
Valve selection	12
Hydraulic features	12
Instructions for use	15
Operation and maintenance instructions	
■ Storage instructions	16
■ Installation instruction	17
■ Operation instructions	19
■ Maintenance instructions	20

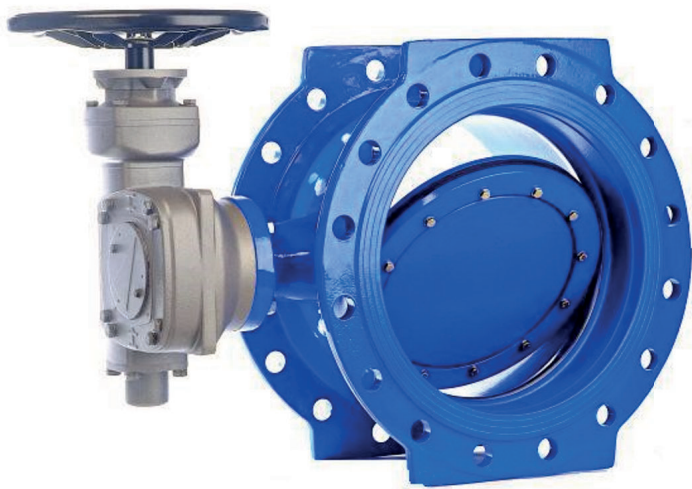

Butterfly Valve Motorizable type

Mod. EUROSTOP

The CSA flanged Butterfly Valve (flange-flange) with joint in the automatic butterfly (JPA) with double eccentricity and long spacing between the flanges.

Applications

- Butterfly valves are isolating valves used on water supply networks, in the interconnections of network, in the factories, in pumping stations, on the general networks and on the fire protection networks in the industrial sites.
- Butterfly valves are compatible with drinking water and raw water with grid filtration. They will be installed on water networks in factories, in valves chambers or buried.
- Their main advantages are:
 - Low pressure loss
 - Good performance thanks to the choice of the materials, the coatings and the design
 - Easy operation per mechanism of the worm type/without end
 - Mechanisms equipped with a standardized flange carry-accessory for buried version and motorizable version

Range

- From DN150 to DN2000mm for pressures of PFA10 to 25 bar

Standards

- Ductile iron body and butterfly covered with blue epoxy powder 250 microns average thickness with a minimum of 200 microns, conforming to EN 14901 (PECB).



Range

The EUROSTOP butterfly valve is available in different configuration: manual, buried service, motorized and motorizable
(for these three last configurations see the specific TDS).

DN valve <i>mm</i>	Closing direction	References PN10	References PN16	References PN25
150	Clockwise	RPB15NHCH	RPB15NHCH	RPB15NHDH
200	Clockwise	RPB20NHBH	RPB20NHAH	RPB20NCDH
250	Clockwise	RPB25NCBH	RPB25NCAH	RPB25NHDH
300	Clockwise	RPB30NCBH	RPB30NHAH	RPB30NCDH
350	Clockwise	RPB35NHBH	RPB35NCAH	RPB35NCDH
400	Clockwise	RPB40NCBH	RPB40NCAH	RPB40NHDH
450	Clockwise	RPB45NCBH	RPB45NHAH	RPB45NCDH
500	Clockwise	RPB50NCBH	RPB50NHAH	RPB50NCDH
600	Clockwise	RPB60NHBH	RPB60NCAH	RPB60NHDH
700	Clockwise	RPB70NCBH	RPB70NCAH	RPB70MHDH
800	Clockwise	RPB80NHBH	RPB80MHAH	RPB80MHDH
900	Clockwise	RPB90MHBH	RPB90MCAH	RPB90MHDH
1000	Clockwise	RPC10MHBH	RPC10MHAH	RPC10MQDH
1200	Clockwise	RPC12MHBH	RPC12MHAH	RPC12MHDH
1400	Clockwise	RPC14MQBH	RPC14MHAH	RPC14MHDH
1500	Clockwise	RPC15MQBH	RPC15MHAH	203216
1600	Clockwise	RPC16MQBH	RPC16MHAH	RPC16MHDH
1800	Clockwise	165541	RPC18MHAH	please contact us
2000	Clockwise	203241	RPC20MHAH	please contact us

Material and coating

Versions DN150-800 PN10 - DN150-700 PN16 - DN150-600 PN25

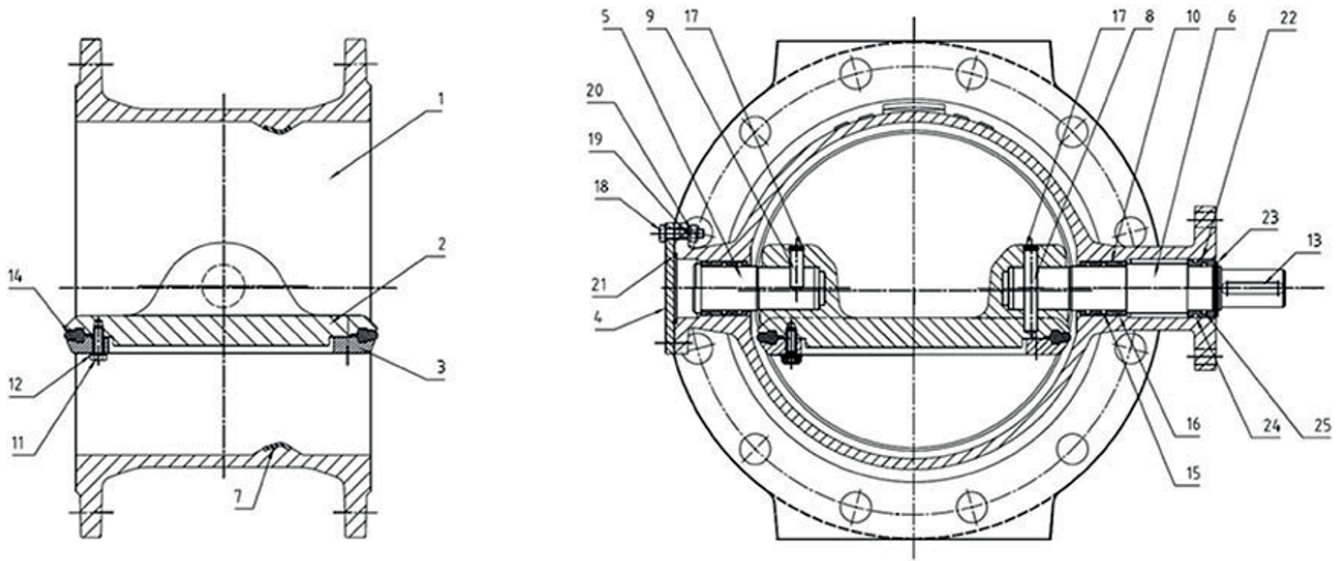

Item	Description	Material	Coating
1	Body	Ductile iron GS500-7	Blue epoxy powder 250 microns average thickness with a minimum of 200 microns, conforming to EN 14901 (PECB).
2	Disc	Ductile iron GS500-7	
3	Retaining ring (*)	Carbon Steel SR235JR	-
4	Cover	Stainless steel X2CrNiMo17-12-2	-
5	Rear shaft	Stainless steel EN 10088 X30Cr13 (420)	-
6	Drive shaft	Stainless steel EN 10088 X30Cr13 (420)	-
7	Seat ring	Stainless steel EN 10088-2 X2CrNiMo 17,12,2 (316L)	-
8	Cylindrical pin (rear shaft)	Stainless steel EN 10088-3 X5CrNiCuNb 16-4 (630)	-
9	Cylindrical pin (drive shaft)	Stainless steel EN 10088-3 X5CrNiCuNb 16-4 (630)	-
10	Bearing	Bronze EN 1982 CuSn12	-
11	Screw	Stainless steel A2	-
12	Spring washer	Stainless steel A2	-
13	Feather key	Steel C40	-
14	Gasket	EPDM	-
15-16	O-ring	EPDM	-
17	Circular circlips	Stainless steel EN 10088-3 X5CrNi 18-10	-
18	Screw	Stainless steel EN 10088-3 X5CrNi 18-10	-
19	Spring washer	Stainless steel EN 10088-3 X5CrNi 18-10	-
20	Nut	Stainless steel EN 10088-3 X5CrNiMo 17-12	-
21	O-ring	EPDM	-
22	Bush	POM-C	-
23	External circlip	Stainless steel EN 10088-3 X5CrNi 18-10	-
24-25	O-ring	EPDM	-

(*) DN150-200 : Stainless steel AISI 316L

Material and coating

Versions DN900-2000 PN10 - DN800-2000 PN16 - DN700-2000

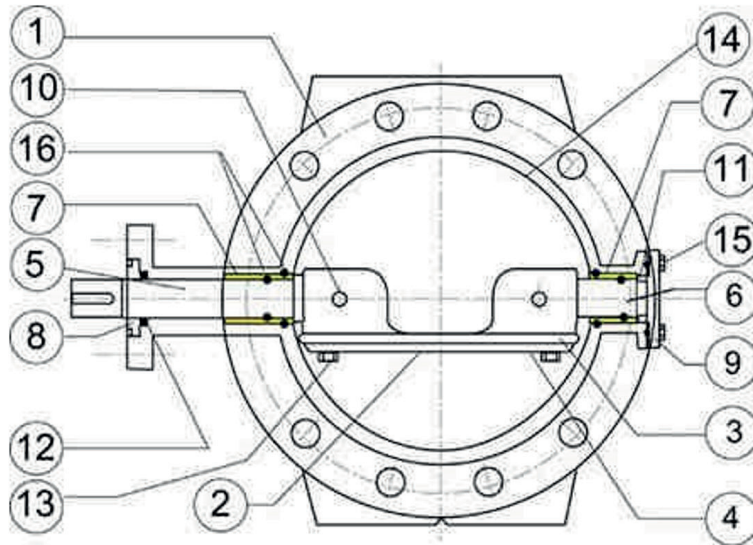

Item	Description	Material	Coating
1	Body	Ductile Iron GS500-7	Blue epoxy powder 250 microns average thickness with a minimum of 200 microns, conforming to EN 14901 (PECB).
2	Disc	Ductile Iron GS500-7	
3	Sealing ring	EPDM	-
4	Retaining ring	Carbon Steel SR235JR	-
5	Shaft	Stainless steel EN 10088 X30Cr13 (420)	-
6	Spindle		-
7	Bearings	Bronze EN 1982 CuSn12	-
8	Ring	Gunmetal EN 1982 CuSn5Zn5Pb5	-
9	Rear cover	Carbon Steel SR235JR	Blue epoxy powder 250 microns average thickness with a minimum of 200 microns, conforming to EN 14901 (PECB).
10	Taper pin	Stainless steel EN 10088-3 X5CrNiCuNb 16-4 (630)	-
11	Lock nut	Gunmetal EN 1982 CuSn5Zn5Pb5	-
12	Sealing element	PTFE	-
13	Internal Screw	Stainless steel type A2	-
14	Body seat ring	Stainless steel EN 10088-2 X2CrNiMo 17,12,2 (316L)	-
15	External Screw	- up to M20: Stainless steel EN 10088-3 - > M20: Steel class 8.8	-
16	O-ring gasket	EPDM	-

Dimensions and mass

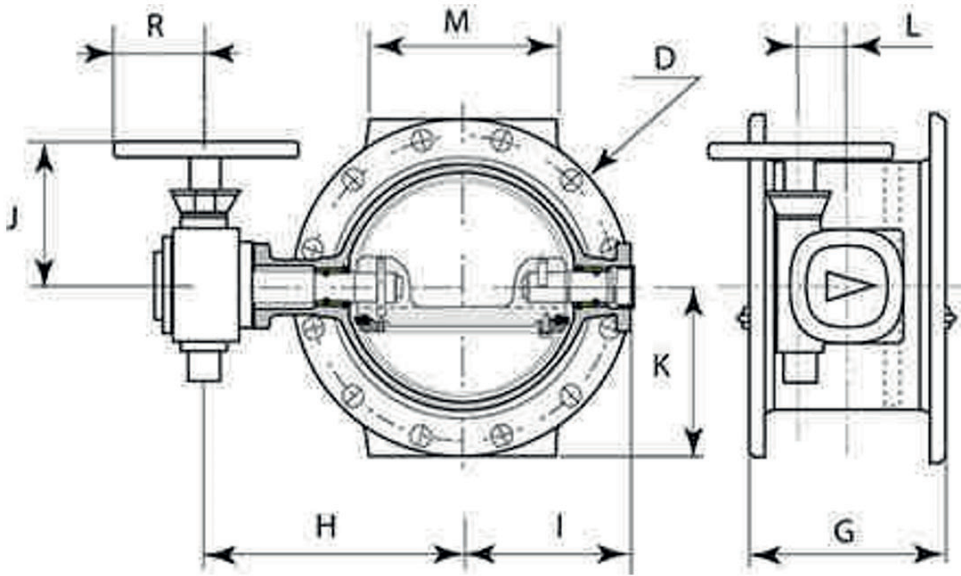

Motorizable Version PN10

DN	G	H	I	J	K	L	M	D	R	Mass
mm	mm	mm	mm	mm	mm	mm	mm	mm	mm	kg
150	210	215	142.9	164	143	50	150	285	100	35
200	230	240	171.0	164	170	50	180	340	100	46
250	250	292	215.3	164	200	50	230	400	100	67
300	270	319	239.3	164	228	50	250	455	100	86
350	290	340	258.3	201	253	63	260	505	125	111
400	310	371	311.4	201	283	63	310	565	125	139
450	330	427	342.4	206	308	80	340	615	125	183
500	350	452	367.4	206	335	80	320	670	125	215
600	390	524	421.4	337	390	100	300	780	175	310
700	430	594	495.5	337	448	100	440	895	175	456
800	470	675	569.5	342	508	125	480	1015	175	640
900	510	724	623	342	558	125	570	1115	175	861
1000	550	815	707	48	615	160	620	1230	175	1249
1200	630	909	842	548	728	200	750	1455	175	1831
1400	710	1051	953	595	838	250	850	1675	250	2512
1500	750	1102	1004	595	893	250	900	1785	250	2873
1600	790	1154	1056	595	958	250	950	1915	250	3470
1800	870	1331	1179	755	1058	315	1000	2115	250	4965
2000	950	1526	1367	848	1173	400	1050	2345	400	6560



Dimensions and mass

Motorizable Version PN16

DN	G	H	I	J	K	L	M	D	R	Mass
<i>mm</i>	<i>mm</i>	<i>mm</i>	<i>mm</i>	<i>mm</i>	<i>mm</i>	<i>mm</i>	<i>mm</i>	<i>mm</i>	<i>mm</i>	<i>kg</i>
150	210	215	142.9	164	143	50	150	285	100	35
200	230	240	171.9	164	170	50	180	340	100	46
250	250	292	215.3	164	200	50	230	400	100	67
300	270	321	239.3	201	228	63	250	455	125	90
350	290	340	280.4	201	260	63	260	520	125	132
400	310	407	322.4	206	290	80	310	580	125	170
450	330	445	342.4	337	320	100	340	640	175	227
500	350	470	367.4	337	358	100	320	715	175	273
600	390	550	451.5	337	420	100	300	840	175	417
700	430	627	521.5	342	455	125	440	910	175	546
800	470	713	602	415	513	160	480	1025	175	926
900	510	764	653	415	563	160	570	1125	175	1152
1000	550	815	748	545	628	200	620	1255	175	1479
1200	630	950	852	622	743	250	750	1485	250	2357
1400	710	1125	973	755	843	315	850	1685	250	3590
1500	750	1156	1077	755	933	315	900	1865	250	4020
1600	790	1229	1119	755	965	315	950	1930	250	4920
1800	870	1431	1272	848	1065	400	1000	2130	400	6974
2000	950	1526	1367	848	1173	400	1050	2345	400	8353

Motorizable Version PN25

DN	G	H	I	J	K	L	M	D	R	Mass
<i>mm</i>	<i>mm</i>	<i>mm</i>	<i>mm</i>	<i>mm</i>	<i>mm</i>	<i>mm</i>	<i>mm</i>	<i>mm</i>	<i>mm</i>	<i>kg</i>
150	210	217	147.9	164	150	50	150	300	100	39
200	230	272	190.3	164	180	50	180	360	100	63
250	250	297	214.3	201	213	63	230	425	125	88
300	270	321	260.4	201	243	63	250	485	125	120
350	290	376	290.4	206	278	80	310	555	125	174
400	310	425	321.4	337	310	100	310	620	175	229
450	330	471	371.4	337	335	100	340	670	175	303
500	350	498	398.5	337	365	100	320	730	175	351
600	390	581	474.5	418	423	160	380	845	175	568
700	430	665	552	418	480	160	470	960	175	975
800	470	713	645	548	543	200	480	1085	175	1243
900	510	788	695	548	593	200	570	1185	175	1693
1000	550	856	756	595	660	250	620	1320	250	2091
1200	630	1024	872	755	765	315	750	1530	250	3430
1400	710	1126	1016	755	878	315	850	1755	250	4067
1500	750	1186	1078	848	933	400	900	1865	400	6052
1600	790	1328	1169	848	988	400	950	1975	400	6200



Gearbox type and handwheel

Motorizable type PN10

DN	Gearbox AUMA type	Handwheel Ø	Number of turns at 90°	Operating torque	Input shaft	Flange
mm		mm		Nm	mm	ISO 5210
150	GS 50.3 – F10	200	12,75	8	16	F10
200	GS 50.3 – F10	200	12,75	12	16	F10
250	GS 50.3 – F10	200	12,75	21	16	F10
300	GS 50.3 – F10	200	12,75	30	16	F10
350	GS 63.3 – F12	250	12,75	39	20	F10
400	GS 63.3 – F12	250	12,75	60	20	F10
450	GS 80.3 – F14	250	13,25	70	20	F10
500	GS 80.3 – F14	250	13,25	90	20	F10
600	GS 100.3+VZ4.3 – F16	350	52	35	20	F10
700	GS 100.3+VZ4.3 – F16	350	52	52	20	F10
800	GS 125.3+VZ4.3 – F25	350	52	77	20	F10
900	GS 160.3+GZ160.3 – F25	350	110,5	47	20	F10
1000	GS 160.3+GZ160.3 – F30	350	110,5	65	20	F10
1200	GS 200.3+GZ200.3 – F30	350	216	60	20	F10
1400	GS 250.3+GZ250.3 – F35	500	212	93	30	F14
1500	GS 250.3+GZ250.3 – F35	500	212	110	30	F14
1600	GS 250.3+GZ250.3 – F35	500	212	130	30	F14
1800	GS 315+GZ30 – F40	500	424	75	20	F10
2000	GS 315+GZ30 – F40	500	424	117	30	F14



Gearbox type and handwheel

Motorizable type PN16

DN	Gearbox AUMA type	Handwheel Ø	Number of turns at 90°	Operating torque	Input shaft	Flange
<i>mm</i>		<i>mm</i>		<i>Nm</i>	<i>mm</i>	<i>ISO 5210</i>
150	GS 50.3 – F10	200	12,75	8	16	F10
200	GS 50.3 – F10	200	12,75	17	16	F10
250	GS 50.3 – F10	200	12,75	29	16	F10
300	GS 63.3 – F12	250	12,75	42	20	F10
350	GS 63.3 – F12	250	12,75	59	20	F10
400	GS 80.3 – F14	250	13,25	83	20	F10
450	GS 100.3+VZ4.3 – F14	350	52	26	20	F10
500	GS 100.3+VZ4.3 – F14	350	52	33	20	F10
600	GS 100.3+VZ4.3 – F16	350	52	59	20	F10
700	GS 125.3+VZ4.3 – F25	350	52	84	20	F10
800	GS 160.3+GZ160.3 – F30	350	110,5	64	20	F10
900	GS 160.3+GZ160.3 – F30	350	110,5	83	20	F10
1000	GS 200.3+GZ200.3 – F30	350	216	65	20	F10
1200	GS 250.3+GZ250.3 – F35	500	212	104	30	F14
1400	GS 315+GZ30 – F40	500	424	65	20	F10
1500	GS 315+GZ30 – F40	500	424	77	20	F10
1600	GS 315+GZ30 – F40	500	424	94	30	F14
1800	GS 400+GZ35 – F48	800	432	126	30	F14
2000	GS 400+GZ35 – F48	800	432	161	30	F14

Gearbox type and handwheel

Motorizable type PN25

DN	Gearbox AUMA type	Handwheel Ø	Number of turns at 90°	Operating torque	Input shaft	Flange
mm		mm		Nm	mm	ISO 5210
150	GS 50.3 – F10	200	12,75	13	16	F10
200	GS 50.3 – F10	200	12,75	28	16	F10
250	GS 63.3 – F12	250	12,75	45	20	F10
300	GS 63.3 – F12	250	12,75	71	20	F10
350	GS 80.3 – F14	250	13,25	88	20	F10
400	GS 100.3+VZ4.3 – F14	350	52	32	20	F10
450	GS 100.3+VZ4.3 – F16	350	52	43	20	F10
500	GS 100.3+VZ4.3 – F16	350	52	59	20	F10
600	GS 160.3+GZ160.3 – F25	350	110,5	47	20	F10
700	GS 160.3+GZ160.3 – F30	350	110,5	70	20	F10
800	GS 200.3+GZ200.3 – F30	350	216	65	20	F10
900	GS 200.3+GZ200.3 – F35	350	216	84	20	F10
1000	GS 250.3+GZ250.3 – F35	500	212	115	30	F14
1200	GS 315+GZ30 – F40	500	424	74	20	F10
1400	GS 315+GZ30 – F40	500	424	110	30	F14
1500	GS 400+GZ35 – F48	800	432	133	30	F14
1600	GS 400+GZ35 – F48	800	432	153	30	F14

Applicable Standards

Hydraulic test

Every single butterfly valve is subjected to hydraulic final test with the purpose of verifying the accordance with the prescriptions ISO 5208:

- Body test at 1,5 time the PFA (open valve);
- Seat test at 1,1 time the PFA (closed valve).

Product test

- Control of manoeuvre torque (MOT and mST) as defined in the EN1074
- Control of coating: test of thickness, holiday test, impact test, MIBK test **Conformity to the standards**

Product

- EN 1074 – 1 and 2
- EN 593
- ISO 10631



Plant test

- ISO 5208

Flanges dimension

- ISO 5752 series 14

Flanges drilling

- EN 1092-2
- ISO 7005-2

Suitability for potable water

- Italian CM 102 of 02/12/78
- Conformity to foreign norms: KTW (Germany), WRC (U.K.), ACS (France)

Marking

On the body like EN19:

- Nominal diameter in mm (DN);
- Nominal pressure in bar (PN);
- Type of ductile iron;
- Manufacturer's logo;
- Model code;
- Fusion date.

On the label like EN19:

- Nominal diameter in mm (DN);
- Nominal pressure in bar (PN);
- Maximum operating pressure (PFA);
- Closing direction;
- Model code;
- Manufacturing order, Order confirmation;
- Manufacturer's logo.

On the disc:

- Nominal diameter in mm (DN);
- Nominal pressure in bar (PN);
- Type of ductile iron; • Manufacturer's logo;
- Model code.

The marking of the valves manufactured by CSA refers to the EN 1074-2 and EN 19 international standards.

Markings are either integral markings, cast in the body, or markings made on plates, securely fixed to the body, in accordance with the EN 19 standard specifications.

Specifications EN19		Requirements	CSA valves process
Table1–Valve markings			
1	DN	EN 19 § 4.2.1 Mandatory markings Shall be integral markings or on a marking plate	Integral
2	PN		Integral
3	Material		Integral
4	Manufacturer's name or trade mark		Plate
11	Reference to Standard	EN 19 § 4.3 Supplementary markings Items 7 to 21 in Table 1 are optional	Integral
12	Melt identification		Integral
16	Quality test		Printed on body
18	Manufacturing date		Plate
21	Closing direction		Plate + sticker on body

Valve selection

The butterfly valves are generally used as isolating devices type on/off. In some particular case, in which there's low differences of pressure and low flow rate variation can be used like regulating devices, considering the hydraulic parameters necessary to avoid the cavitation risk.

To do the right dimensioning of butterfly valve it's necessary to know the followings parameters:

- Upstream hydrostatic pressure (that is the hydrostatic pressure with valve in closed position)
- The maximum speed in water pipe (generally expressed in l/s) or the nominal diameter and the project flow rate from which it is gained the speed $V=Q/A$

Moreover, it's necessary to control that the maximum speed in water pipe have to be equal or inferior to 5m/s, and the exercise temperature have to be between 0°C and 40 °C.

Hydraulic features

The head loss Δh are variable in function of valve open degree and can be calculated with the following expression:

$$\Delta h = \frac{\zeta \cdot v^2}{2 \cdot g}$$

with Δh = head loss (m), ζ = head loss coefficient (dimensional), v = nominal speed (m/s), $g = 9,81$ (m/s²)

The head loss coefficient can be estimated from this diagram:

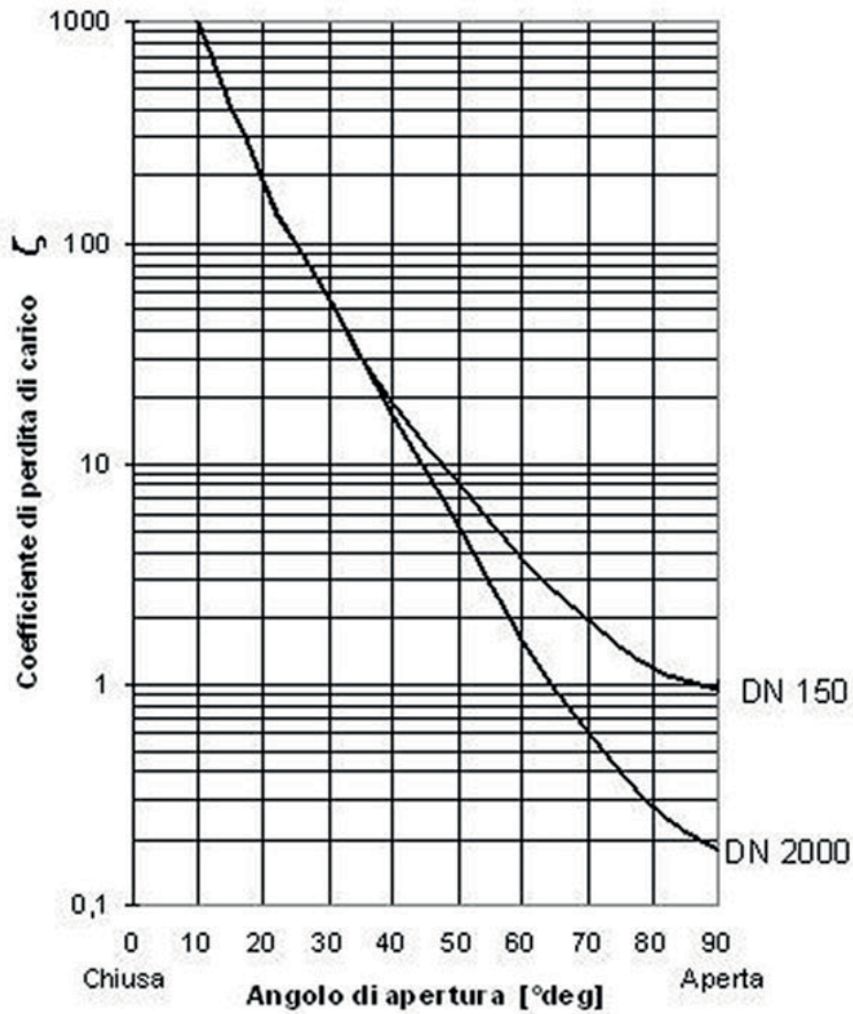

Determinates the head loss Δh it's possible to calculate the flow rate Q in m^3/h with the following expression (the same expression can be used to, having the project flow rate Q , to determinate the head loss Δh without using the head loss coefficient):

$$Q = \frac{K_v}{\sqrt{10.2}} \sqrt{\Delta h}$$

in which 10,2 is a corrective factor in meters, and K_v is the flow rate coefficient in m^3/h , determinable from the following diagram in function of valve open degree:

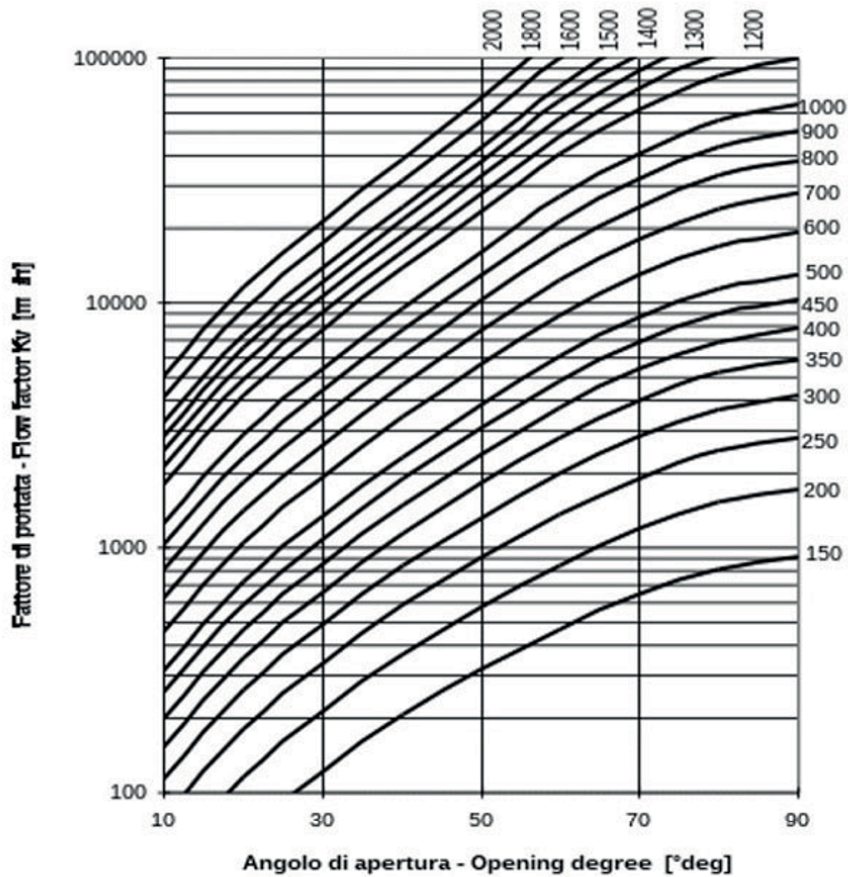

Example: Valve DN=100 mm $Z_1 - Z_2 = 0$ m.

From the diagram with valve open to 100% the coefficient K_v is 20000 m^3/h . Using this date in the flow rate expression:

$$Q = 20000 \times \sqrt{3/10,2} = 10850 \text{ m}^3/\text{h}$$

Otherwise it's possible to calculate the head loss with valve completely open, having the project flow rate Q , in function of DN, using the following diagram:

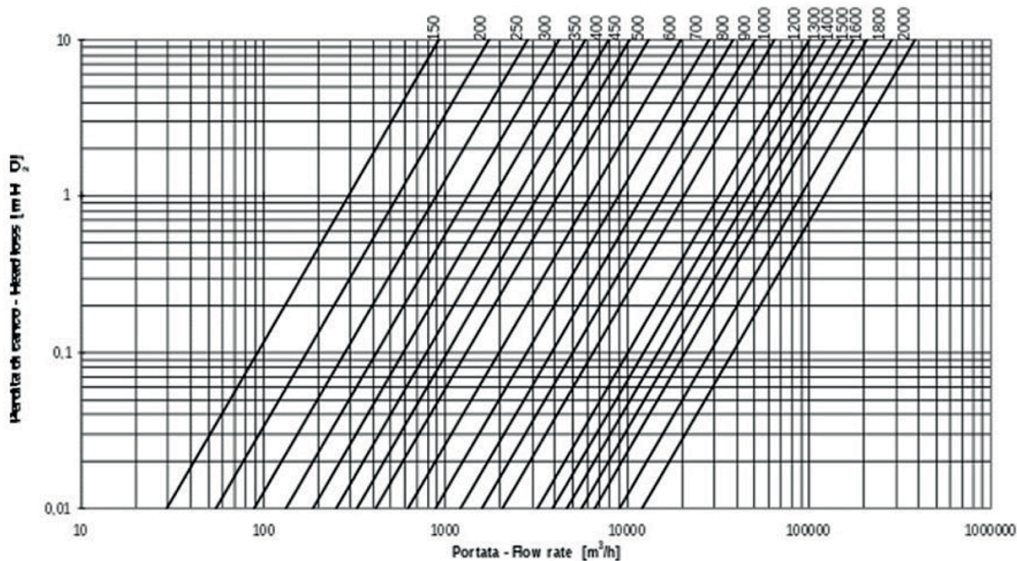

Cavitation

If the butterfly valve is used only like isolating device there's not cavitation risk. In the particular case in which it's used like regulating device, this can be possible only respecting the following parameters:

- The valve open degree has to be between 30° and 90° (valve completely open)
- The downstream pressure P_2 have to be: $P_2 \geq 0,7 \cdot P_1 - 2,8$ with P_1 upstream pressure.



Instructions for use

Storage

The butterfly valve will have to be held (if possible) in covered places, the most possible protected from the sun (maximum allowable temperature 70°C in accordance to EN 1074), from the rain and generally from the atmospheric agents. Moreover, it will have to be avoided that the seal of the same air valves come to contact with powder or earth.

Installation

The butterfly valves are generally installed with retaining ring mounted in the opposite way respect to the direction of flow rate to permit the substitution of gasket without dismounting the valve from pipeline. In any case it is possible to install the butterfly valve with flow rate in opposite direction and also, if required, in vertical position. We recommend to install the butterfly with the operating device on the hydraulic right side of pipeline.

It's possible to install the butterfly valve both in chamber valve that underground (choosing the right configuration).

We recommend to insert a dismounting joint for the operation of maintenance.

Maintenance

The butterfly valve does not require a particular maintenance, all parts subjected to wear are perfectly auto-lubricating. In any case, if for a long time will be not used, it is necessary to evaluate the functioning of valve doing (at least one time for year) some manoeuvre of opening-closing.

All the maintenance operation has to be done after the total emptying of pipeline (no flow rate and pressure) to avoid every risk to the people during this operation.

In presence of particularly exercise condition or damage due to external cause, it will be necessary some maintenance operation. In this case the particular shape of EUROSTOP butterfly valve permits the simple gasket substitution without the dismounting of valve from pipeline (if the dismounting joint is present).

Accessories

To adapt the butterfly valves to the different exercise and installation conditions required, they can be equipped with particular accessories used in combination with control devices: please refer to data sheet for accessories.

The technical features in this document are not contractual and can be changed without preliminary notification due to the continuous technical progress of product.



OPERATION AND MAINTENANCE INSTRUCTIONS

Storage instructions

Handling

The handling of the valve has to be made with care, in order to avoid any shock, even accidental, which could damage it. In particular any lift of the valve should be carried out paying attention that the chain, cable or rope used for that specific operation is not clamped or does not touch the shafts, the gearbox or its handwheel. For this task the ends of the valve body or the flanges should be used.

It is absolutely forbidden to use the eventual hook(s) of the actuator to lift the valve.

NOTE: For possible future interventions on the internal parts of the valves it is strongly recommended laying every actuated (or to be actuated) valve together with a dismantling joint. Please consult CSA for these products.

Storage

Generally the valves are supplied with plugs at the extremities, or in pallets banded with plastic film; if the valves are without packing and have to stay for long time in the stock before being install, they must be stocked covering the passage of the valve, safeguarding in this way the interior parts and particularly the seat from the contact with powder or dirt.

The valves shall be stored in a location offering a good protection against direct sun, the rain and all other atmospheric elements (admissible storage temperature. -20°C to $+70^{\circ}\text{C}$). The rubber components are sensitive to the light and the sunbeam. In absence of a storage place the valves have to be wrapped with a cellophane or plastic sheet, possibly of dark color. The butterfly valve must be always stored (and later on installed between flanges) with the disc in a slightly opened position. All butterflies valves are delivered with disc in this position.

The valves must not weight on the shaft or on the gearbox, and if the valves have to be stacked one on the other, it's important to pay attention that the coated surfaces don't come directly in contact: a cardboard between the surfaces should be used.

Accessories and spare storage

Gasket

Normally the seal ring of the disk is made with a rubber quality which is sensitive to the sunlight. Therefore it is usual to store such rubber part in an area protected from the sunlight, in order to avoid its deterioration. If such conditions are not available, rubber parts should be then at least protected by cellophane or plastic sheets of dark color.

Bolts

The requested flange bolting is normally packed in a sack or a box equipped with a tag indicating the number and the type of the packed bolts. It is absolutely necessary to keep them in the original condition of delivery, avoiding putting them in contact with material which could damage them. Generally the bolting is slightly lubricated before delivery; any contact with dirt or dust could, in extreme cases, damage the threads and prevent its future mounting.



Actuators

For this particular type of accessory, which is generally mounted on the valve at the time of the delivery,, it is necessary to pay attention that nobody, with the exception of the specialist or authorized people, could attempt to repair or manipulate it, this would take out any warranty covering these specific components.

It is very important to check that the threaded orifices permitting the future electric/hydraulic/pneumatic connections are always well protected with the original plugs until their use in final assembly.

This will insure that no dirt, dust, humidity or any other external particle will damage the internal parts (gears, electrical coils, pistons, cylinders, seats, etc.).

When the electrical wiring is not made immediately after the mechanical mounting of the valve in the pipe system, the installer/contractor will take the necessary measure to protect correctly and thoroughly the actuator against any atmospheric degradation and the built-up of condensation. Furthermore it is necessary to check periodically during this particular period of time the status of internal components, by removing the covers of the operative unit and of the reduction unit, protecting with silicone or oil vaseline the respective cover gaskets when remounting them.

Installation instructions

Preliminary inspections

Before mounting the valve in the pipeline, it is always advisable to:

control that no dirt or dust or external particles are contained in the valve body and in particular that the valve seat is clean. Every clamping screw (mounted inside or outside the valve) should be checked and any loosened screw should be tightened.

The valve should not be operated dry and before the final pipeline assembly and the final contact with the fluid.

In case of valve long term storage follow the guidelines here below:

Valves to be stored in a clean, dry protected warehouse, free from rapid temperature changes.

Visual inspection shall be performed and it shall include the packaging, Covers, Dryness, Cleanliness, and the sealing status.

Check the lubrication state of the gasket and put some lubricant suitable to get in contact with drinking water. Make (after the valve has been lubricated) one complete cycle of opening/closing of the valve has to be made in order to check that all components ensuring this specific operations are working correctly.

The valve should be operated on a monthly basis.

If valve is to be stored for 3 years or longer, the main seal must be changed after 3 years of storage.

Mounting

The mounting of every valve has to be effectuated without pressure in the pipe. A sufficient space should be provided around the valve to permit its usual operation, as well as any eventual setting or future maintenance work.

It is usually foreseen to include in the mounting procedure of a valve a dismantling joint. The device is normally mounted in the downstream side of the valve. Thanks to its adjustable length range it's not needed a very precise mounting between the pipe flanges. When used at the downstream side of a butterfly valve, it allows, when removed off the pipe, to check the internal wear level and/or to change the seat ring of the valve, without taking it out of the pipe.



The EUROSTOP butterfly valve is bidirectional and may be installed with flow in either direction.

In any case the butterfly valves are generally mounted with the disc gasket downstream (with the control device on the right hydraulic side) to permit its replacement without removal the valve from the pipe (dismantling joint downstream).

The EUROSTOP butterfly valve may be installed either vertically or horizontally, in a straight length of pipe will not create a problem and hydraulically will make no difference

However care must be taken in case of contaminated waters, for example water containing sand, gravel, rust, lime and so on.

If a choice of stem position exists, the valve should be installed with the stem in the horizontal position; this will minimize seat wear by distributing the stem and disc weight evenly. Also, if the media is abrasive, the horizontal stem position creates a self-flushing effect that will extend the service life-expectancy of the valve.

The pipeline should be as free as possible from welding, scraps, mounting accessories, dirt, etc. The cleanest the pipe is kept during the installation, the less trouble will be produced. Afterwards if the transported fluid in the system contains a lot of external solid particles, it's recommended to install in the upstream side of the valve a strainer.

Both pipe flanges, which are connected to the valve, should be located perfectly in the centerline of the pipe and absolutely parallel. If no dismantling joint is used in the mounting procedure of the valve, the distance between the two pipe flanges should match the overall length given by the valve manufacturer including twice the thickness of the flange gaskets. Any longer distance between the two pipe flanges (even of some mm) can produce during the tightening of the flange bolts/nuts very high yield stress on the valve.

The centring can be made visually with the surface of the flange. The bolts have to be clamped gradually in alternate way.

The gearboxes of the EUROSTOP manual version are set and tested in factory after the assembly on the valve.

If the valves have an electric actuator, it's necessary to check the manual installation of the producer. Before the installation it will be necessary to realize the electric control board (if not required on the order) and to do the electric connections.

The electric connections have to be made verifying the right positioning of motor phases, following the wiring drawing, to avoid the opposite rotation that can cause also damages to the valve.

In this case a closing rotation will push the disc against the body seat, but if the limit or torque switch will not work, the mechanical effort created by the motor will produce the rupture of one of the components forming the driving assembly (gearbox, motor, valve).

NOTE: For possible future interventions on the internal parts of the valves it is strongly recommended laying every actuated (or to be actuated) valve together with a dismantling joint. Please consult CSA for these products.

The EUROSTOP butterfly valve is equipped with standard AUMA GS type gearbox position 2 like indicated in the N FE 29-431 Norm.

Other gearbox positions are available upon request

**POSITIONS POSSIBLE DU MECANISME VANNE OUVERTE PAR RAPPORT A LA NORME NFE 29431
AVEC COMMANDE A L'ENTREE FAH OU FSH**

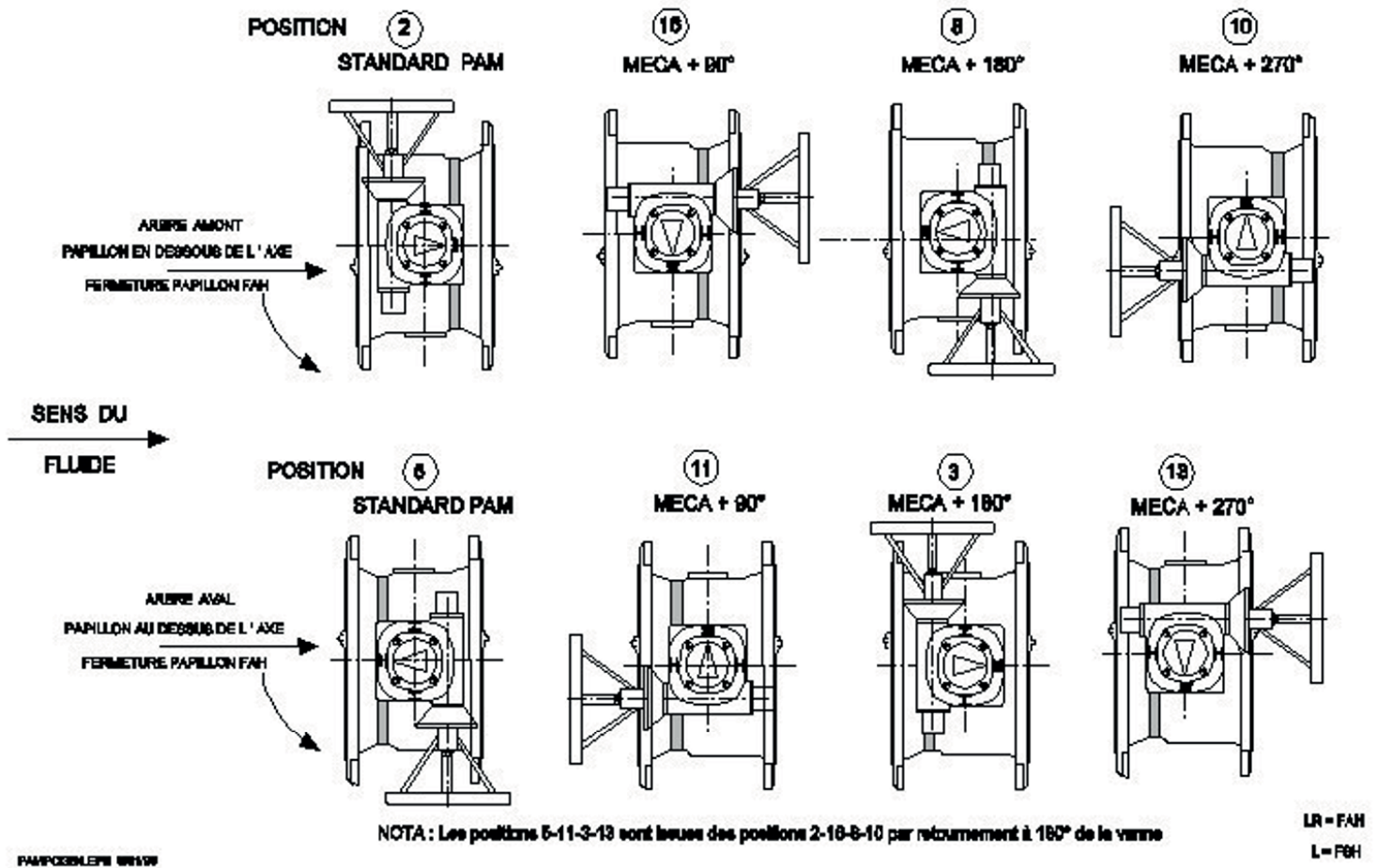

Start Up

After the mounting of the valves on the pipeline it must be verified that the coating has not been damaged. So, it's advised to repair the coating to avoid the formation of rust.

In case of motorized version, normally the electrical actuator is tested and set-up in the factory when it is assembled with the butterfly valve. However, after having checked thoroughly the electrical wiring, it's necessary to operate the valve a few times for controlling its perfect operation. It is further recommended to start the electrical tests with the disc in the intermediate opened position to check that the closing operating switch signal is effectively corresponding to the closing of the valve disc without damaging any component of the driving assembly.

Operation instructions

Manoeuvre

The manoeuvre of the valve is driven by a worm type gearbox mounted externally to the body and connected through the shaft.

The gear is needed to realize a gradual movement to avoid the water hammer effect. To open and close it rotates of 90°.

In case of electric actuator, the time of manoeuvre has to be communicated from the customer at the time of the order (it will be not take responsibility for further modification).

The standard UNI EN 1074-1-2 fixes the maximum admissible torque C_{max} during the manoeuvre without damaging of the valve (example: with handwheel $C_{max} = F \cdot D_{handwheel}$ where F is the applied force).

Service conditions

The standard UNI EN 1074-1-2 fixes the maximum speed of water in the valve:

PFA (bar)	10	16	25
Max speed of water (m/s)	3	4	5

The same standards fixes also the admissible temperature of water: from 0°C (excluded freezing) to 50°C.

The butterfly valve is an isolating device, so it's designed to work completely closed or open. Partial flow introduces cavitation and friction troubles. Particularly they occur when the opening degree is below 30° and if the pressure condition is $P_{downstream} < (0,7 \cdot P_{upstream} - 0,28 \text{ bar})$

Maintenance Instructions

Ordinary maintenance

The butterfly valves EUROSTOP are designed, manufactured and tested to guarantee the maximum liability and endurance. In the standard version the choosing of materials is made paying attention to usual type of fluid and the common exercise condition: all the parts do not necessitate of particularly maintenance. If the valves must work in extreme conditions, special version must be ordered.

The efficiency of hydraulic equipments during their life is generally connected to the exercise conditions and to the type of fluid. It's advised to plan periodical inspection according to the type of valve and to the main function of the same valve.

For the butterfly valves, to maintain the performances in the time, it's needed to do at less one complete cycle of opening/closing manoeuvre every year to reduce incrustations and sediments that can accumulate during the exercise.

If the butterfly it's used also to regulate the flow, it's necessary to verify periodically the conditions of body and seat.



Operation	1	2	3	4	5	After 5 years
Cycle of manoeuvre (op. – cl.)	yes	yes	yes	yes	yes	One cycle every year
Verify the clamping of bolts of yes flanges and gearbox	yes	yes	yes	yes	yes	Control at every inspection
Verify seat and body (if the valve is used for regulation)	yes	yes	yes	yes	yes	Control at every inspection

Extraordinary maintenance

In presence of particular exercise conditions (not filtered or particularly aggressive water, incrustations) or damage due to external cause, it's possible that extraordinary maintenance operations are needed.

The operation of extraordinary maintenance that can be made directly on site is the replacement of disc gasket seal. Moreover the shaft sealing kit is available for the replacement of shaft gaskets. Other operations (replacement of the disc, shaft, ...) are very exceptional and are not explained in this manual (in any case they are possible contacting our technical department).

For any extraordinary maintenance operations on gearboxes and/or electrical actuators please refer to operation and maintenance instructions of manufacturer.

All these operations have to be effectuated after the complete emptying of the pipe (total absence of pressure) to avoid any risk to the people during this operation.

Remember to remove gradually the bolts only after the clamping of the valve lifting device.

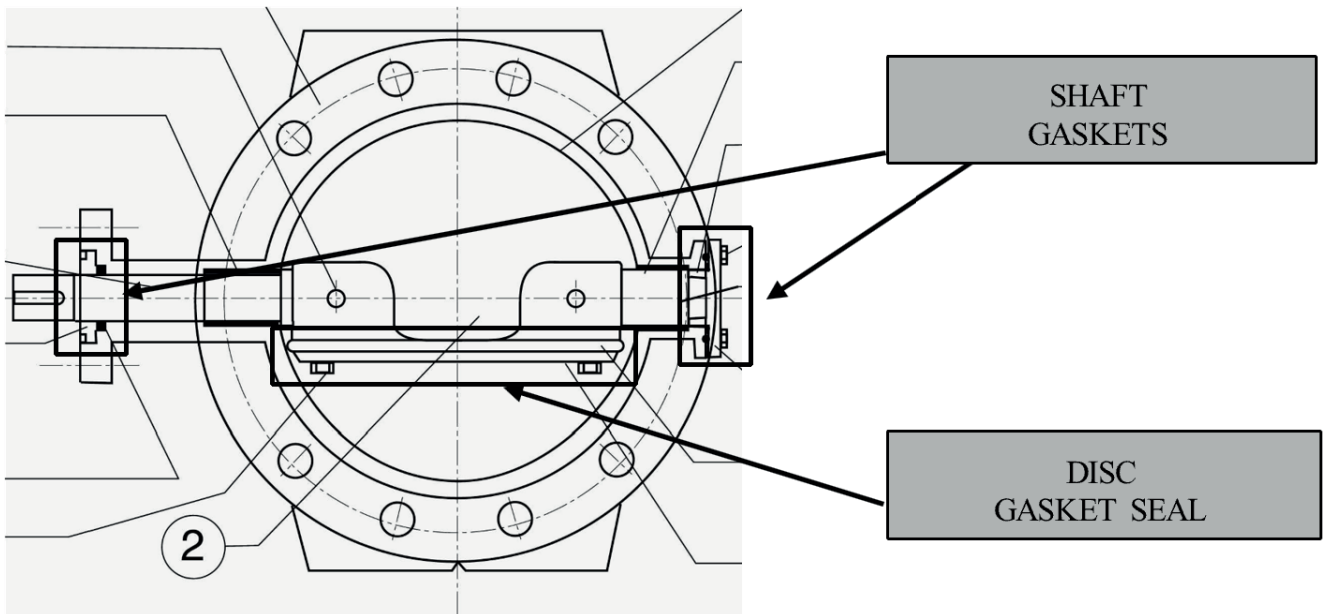

Other interventions

DISC GASKET SEAL REPLACEMENT

Please refer to the technical data sheet of spare parts for details.

SHAFT GASKETS REPLACEMENT

Please refer to the technical data sheet of spare parts for details.

NOTE

For any further information or clarification consult CSA.